

# JHP FASTENERS, INC

## FLANGE WELD NUT

### SERIES

### JPWF INCH STEEL / PLAIN

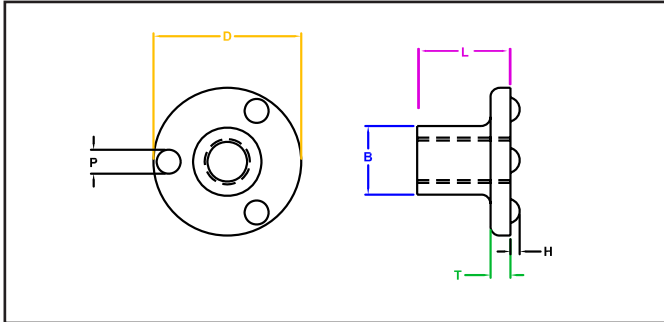

**JPWF Series - This Flange Weld Nut with 3 projections on the flange enables welding the nut to the surface, as opposed to through the material. Made from a high-welding quality low carbon steel.**

Part Number	Thread Size	L Length Overall ±0.010	B Body Diameter ±0.004	Flange		Projection	
				D Diameter ±0.015 *(+0.015/-0.020)	T Thickness ±0.005	P Diameter ±0.005	H Height ±0.002
WF 1105	#6-32	0.317	0.214	0.495	0.063	0.080	0.030
WF 1405	#8-32	0.317	0.247	0.495	0.063	0.080	0.030
WF 1537	#10-24	0.380	0.274	0.615	0.085	0.100	0.040
WF 1637	#10-32	0.380	0.274	0.615	0.085	0.100	0.040
WF 2150	1/4-20	0.505	0.371	0.800	0.109	0.130	0.050
WF 2709	5/16-18	0.567	0.446	0.990*	0.125	0.150	0.060
WF 3310	3/8-16	0.630	0.496	0.990*	0.125	0.150	0.060

All Dimensions are in Inches

JHP Fasteners, Inc. 610 Maryland NE - Suite B Grand Rapids, MI 49505	Drawing No <b>JPWF</b>	P - 800.783.0910 P - 616.913.0060 F - 616.913.0085
Scale NTS	Revision	Drawn by: M McCormick

# JHP FASTENERS, INC

## FLANGE WELD NUT

### SERIES

### JPWFZ INCH STAINLESS / PLAIN

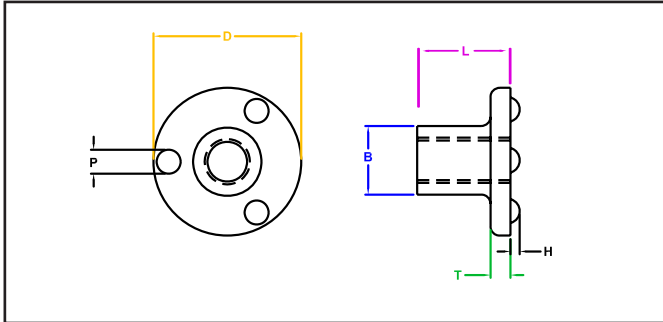

**JPWFZ Series - This Flange Weld Nut with 3 projections on the flange enables welding the nut to the surface, as opposed to through the material. Made from 18-8 stainless steel.**

Part Number	Thread Size	L Length Overall ±0.010	B Body Diameter ±0.004	Flange		Projection	
				D Diameter ±0.015 *(+0.015/-0.020)	T Thickness ±0.005	P Diameter ±0.005	H Height ±0.002
WFZ 1105	#6-32	0.317	0.214	0.495	0.063	0.080	0.030
WFZ 1405	#8-32	0.317	0.247	0.495	0.063	0.080	0.030
WFZ 1537	#10-24	0.380	0.274	0.615	0.085	0.100	0.040
WFZ 1637	#10-32	0.380	0.274	0.615	0.085	0.100	0.040
WFZ 2150	1/4-20	0.505	0.371	0.800	0.109	0.130	0.050
WFZ 2709	5/16-18	0.567	0.446	0.990*	0.125	0.150	0.060
WFZ 3310	3/8-16	0.630	0.496	0.990*	0.125	0.150	0.060

All Dimensions are in Inches

JHP Fasteners, Inc. 610 Maryland NE - Suite B Grand Rapids, MI 49505	Drawing No <b>JPWFZ</b>	P - 800.783.0910 P - 616.913.0060 F - 616.913.0085
Scale NTS	Revision	Drawn by: M McCormick

# JHP FASTENERS, INC

## FLANGE WELD NUT

### SERIES

JPWFM  
METRIC  
STEEL / PLAIN

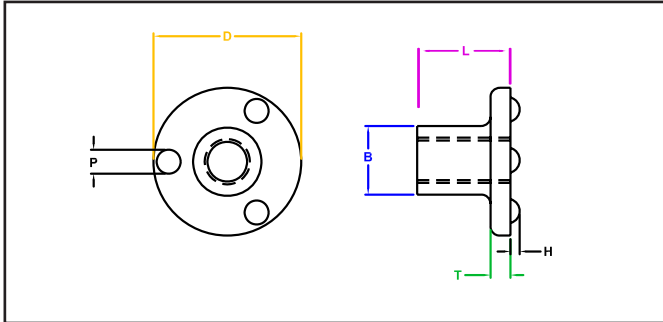

**JPWFM Series - This Flange Weld Nut with 3 projections on the flange enables welding the nut to the surface, as opposed to through the material. Made from a high-welding quality low carbon steel.**

Part Number	Thread Size	L Length Overall +0.20/-0.30	B Body Diameter ±0.10	Flange		Projection	
				D Diameter ±0.35*(±0.45)	T Thickness ±0.13	P Diameter ±0.13	H Height ±0.05
WFM 03507	M3.5-6H	7.50	5.30	12.00	1.90	1.78	0.64
WFM 04008	M4-6H	8.00	6.30	14.00	2.20	2.13	0.81
WFM 05010	M5-6H	10.00	7.10	16.00	2.50	2.54	1.02
WFM 06012	M6-6H	12.50	9.00	20.00*	3.10	3.10	1.20
WFM 08015	M8-6H	15.00	11.30	25.00*	3.80	3.56	1.40
WFM 10017	M10-6H	17.00	13.40	27.00*	4.50	3.81	1.52

All Dimensions are in Millimeters

JHP Fasteners, Inc. 610 Maryland NE - Suite B Grand Rapids, MI 49505	Drawing No <b>JPWFM</b>	P - 800.783.0910 P - 616.913.0060 F - 616.913.0085
Scale NTS	Revision	Drawn by: M McCormick