

JHP FASTENERS, INC

FLANGE WELD NUT

SERIES

**JPRH
INCH
STEEL / PLAIN**

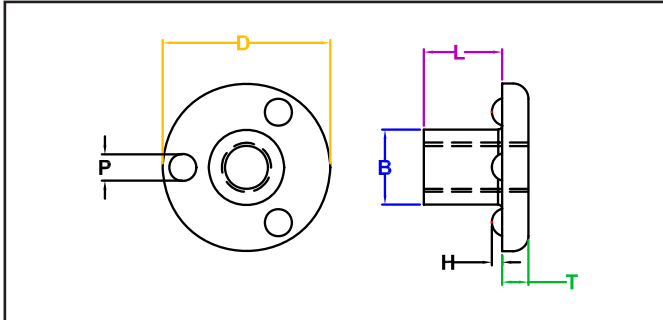

JPRH Series - Self-locating Flange Weld Nut designed for thru-the-hole installation with 3 projections under the head. Made from a high-welding quality low carbon steel.

Part Number	Thread Size	L Length Under Flange ±0.010	Flange		B Body Diameter ±0.003 *(±0.004)	Projection	
			D Diameter ±0.015 *(+0.015/-0.020)	T Thickness ±0.005		P Diameter ±0.005	H Height ±0.002
RH 1104	#6-32	0.255	0.62	0.078	0.247	0.100	0.040
RH 1404	#8-32	0.255	0.62	0.078	0.247	0.100	0.040
RH 1505	#10-24	0.317	0.74	0.094	0.274	0.120	0.045
RH 1605	#10-32	0.317	0.74	0.094	0.274	0.120	0.045
RH 2138	1/4-20	0.380	0.82	0.125	0.371*	0.130	0.050
RH 2708	5/16-18	0.505	0.99*	0.141	0.446*	0.150	0.060
RH 3308	3/8-16	0.505	0.99*	0.141	0.496*	0.150	0.060

All Dimensions are in Inches

JHP Fasteners, Inc. 610 Maryland NE - Suite B Grand Rapids, MI 49505	Drawing No JPRH	P - 800.783.0910 P - 616.913.0060 F - 616.913.0085
Scale NTS	Revision	Drawn by: M McCormick

JHP FASTENERS, INC

FLANGE WELD NUT

SERIES

JPRHZ

INCH

STAINLESS / PLAIN

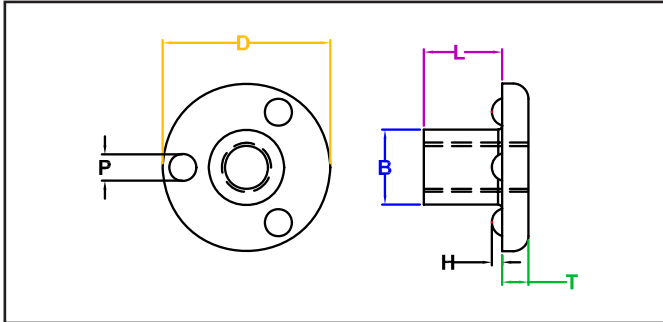

JPRHM Series - Self-locating Flange Weld Nut designed for thru-the-hole installation with 3 projections under the head. Made from 18-8 stainless steel.

Part Number	Thread Size	L Length Under Flange ±0.010	Flange		B Body Diameter ±0.003 *(±0.004)	Projection	
			D Diameter ±0.015 *(+0.015/-0.020)	T Thickness ±0.005		P Diameter ±0.005 *(±0.010)	H Height ±0.002 *(+0.005)
RHZ 1104	#6-32	0.255	0.620	0.078	0.247	0.100	0.040
RHZ 1404	#8-32	0.255	0.620	0.078	0.247	0.100	0.040
RHZ 1505	#10-24	0.317	0.740	0.094	0.274	0.120	0.045
RHZ 1605	#10-32	0.317	0.740	0.094	0.274	0.120	0.045
RHZ 2138	1/4-20	0.380	0.820	0.125	0.371*	0.130	0.050
RHZ 2708	5/16-18	0.505	0.990*	0.141	0.446*	0.150	0.060
RHZ 3302	3/8-16	0.505	0.990*	0.141	0.496*	Width: 0.090*	0.030*

All Dimensions are in Inches

JHP Fasteners, Inc. 610 Maryland NE - Suite B Grand Rapids, MI 49505	Drawing No JPRHZ	P - 800.783.0910 P - 616.913.0060 F - 616.913.0085
Scale NTS	Revision	Drawn by: M McCormick

JHP FASTENERS, INC

FLANGE WELD NUT

SERIES

**JPRHM
METRIC
STEEL / PLAIN**

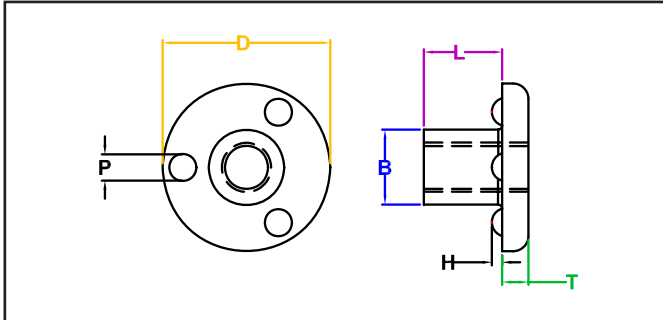

JPRHM Series - Self-locating Flange Weld Nut designed for thru-the-hole installation with 3 projections under the head. Made from a high-welding quality low carbon steel.

Part Number	Thread Size / Pitch	L Length Under Flange +0.20/-0.30	Flange		B Body Diameter ±0.10	Projection	
			D Diameter ±0.30 *(±0.40)	T Thickness ±0.05		P Diameter ±0.13	H Height ±0.13
RHM 03506	M3.5 X 0.6-6H	6.0	15.80	1.98	6.3	2.54	1.02
RHM 04006	M4 X 0.7-6H	6.3	15.80	1.98	6.3	2.54	1.02
RHM 05008	M5 X 0.8-6H	8.0	18.80*	2.50	7.1	3.10	1.20
RHM 06010	M6 X 1-6H	10.0	20.90*	3.10	9.0	3.30	1.27
RHM 08013	M8 X 1.25-6H	12.9	25.00*	3.60	11.3	3.56	1.40
RHM 10014	M10 X 1.5-6H	14.0	27.00*	4.50	13.4	3.81	1.52

All Dimensions are in Millimeters

JHP Fasteners, Inc. 610 Maryland NE - Suite B Grand Rapids, MI 49505	Drawing No JPRHM	P - 800.783.0910 P - 616.913.0060 F - 616.913.0085
Scale NTS	Revision	Drawn by: M McCormick